

Dual 2X2 Half Duplex Switch

A precision, moving fiber, optical switch, the D22HC utilizes direct fiber-to-fiber coupling over an angled gap to achieve ultra low losses and wavelength independence. It is suitable for all bi-directional protection switching applications where premise-side connectivity is not required in the bypass state (state 2). Compact and comprehensive, the D22HC provides excellent value per dollar.

Note: This switch includes an extra path when compared to a typical half duplex switch (see connectivity diagram on back).

FEATURES

- Two Half Duplex 2X2's in one package
- Compact Format (with cables on one side)
- Low Loss (< 0.10dB typical MM)
- Low Back Reflection
- Multimode or Singlemode
- Wavelength Independent
- PCB Mountable
- Latching or Non-Latching
- High Reliability



LOW LOSS

This switch achieves exceptionally low loss by physically moving fibers to align with other fibers. For multimode, losses are typically less than 0.10dB!

WAVELENGTH INDEPENDENCE

Wavelength independence is another benefit of the moving fiber design. Because there are no mirrors, lenses, AR coatings, or epoxy, the same switch can be used for multiple wavelengths.

ORDERING INFORMATION

D22HC-X-X-X-X-X-X

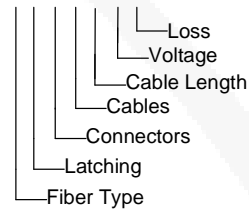

Fiber Type

- S1** Singlemode 9/125 (Standard)
Corning SMF-28 9/125 or equivalent
- M1** Multimode 62.5/125
- M2** Multimode 50/125
- M3** Multimode 100/140

Latching

- L** Yes (Standard)
Latching switches require no steady state input power. The switch is set to state 1 or state 2 by a single pulse of 20 milliseconds or longer. Continuous current is preferable to maintain the switched state under high vibrational stress. The latching design retains its switched state during a power loss.
- N** Non-latching (Power OFF = State 1, Power ON = State 2)
- NR** Non-latching Reverse (Power OFF = State 2, Power ON = State 1)
Non-latching switches require continuous drive current and functions like a conventional relay, which may not retain state during a power loss.

Connectors

- NC** none (Standard)
Also known as pigtailling
- FC** FC/PC
- SC** SC/PC
- ST** ST/PC
- LC** LC/PC
- STU** ST/UPC
Ultra polish
- DLC** Duplex LC/PC

Cables

- 1** 900µm Tight Buffer (Standard)
900µm tight buffered tube

Cable Length

- 1** 1.0 Meter (Standard)
- 2** 0.5 Meter
- 3** 2.0 Meters

Voltage

- 5** 5V (Standard)
Requires a minimum of 4.2V. Low voltages will result in reduced switch speed.
- 3** 3V
Requires a minimum of 2.5V. Low voltages will result in reduced switch speed.
- 5H** 5V High Current
Requires a minimum of 4.2V. Recommended for better latching when power consumption is not an issue.

Loss

- L** Low (Standard)
Typical 0.25 dB loss for singlemode, 0.05-0.10 dB loss for multimode. Utilizes a discrete amount of matching fluid at the gap.
- N** Normal
Typical 0.7 dB loss for singlemode, 0.5 dB loss for multimode. Features an air gap.

DRAWINGS

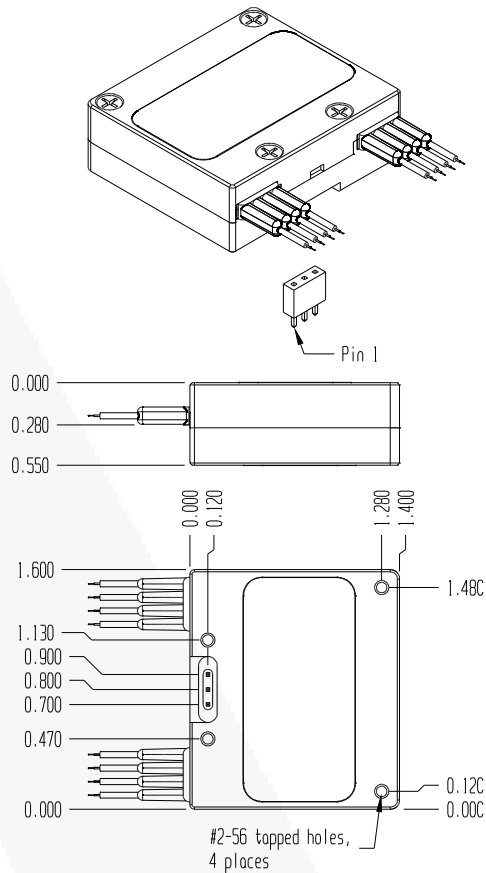

ELECTRICAL CONNECTIVITY

Switch Type	State 1			State 2		
	Pin 1	Pin 2	Pin 3	Pin 1	Pin 2	Pin 3
Latching	V+	Gnd	V = 0	V = 0	Gnd	V+
Non-latching	Gnd	N/C	V = 0	Gnd	N/C	V+

FIBER CONNECTIVITY

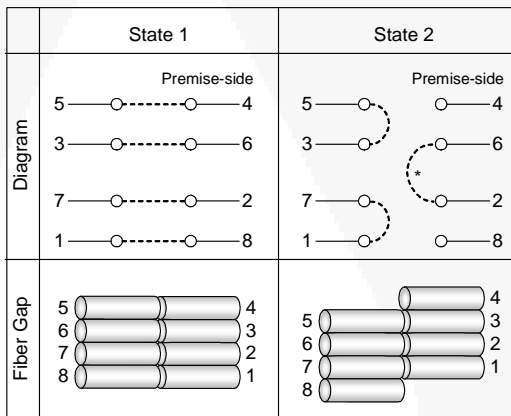

*Although most applications do not require the connection between 6 and 2 in state 2, it is not an issue and in some cases may be a desired feature.

SWITCH SPECIFICATION SUMMARY

Optical Characteristics		Singlemode 9/125 μm		Multimode 62.5/125 μm		Units	Notes
		Low Loss	Normal Loss	Low Loss	Normal Loss		
Insertion Loss 1550 nm	Typical	0.35	0.7	0.05	0.5	dB	1
	Maximum	0.7	1.2	0.20	0.8		
Insertion Loss 1310 nm	Typical	0.25	0.8	0.05	0.5	dB	1
	Maximum	0.6	1.3	0.20	0.8		
Insertion Loss 850 nm	Typical			0.10	0.6	dB	1
	Maximum			0.25	0.9		
Back Reflection	Typical	-65	-60	-60		dB	
	Minimum	-55	-50	-50			
Cross-talk	Max			-70		dB	4
Switching Time	Typical			7			
	Max at 25 °C			10			
	Max 0 to 70 °C			12			

Stability		Singlemode 9/125 μm		Multimode 62.5/125 μm		Units	Notes
		Low Loss	Normal Loss	Low Loss	Normal Loss		
Lifetime Drift	Max @ 10 ⁶ cycles			+/- 0.2		dB	
Repeatability	Maximum			0.01			
Optical Power	Maximum	+17	+20	+20	+23	dBm	5
Temperature Range	Operational			0 to 70 °C			
	Storage			-30 to 70 °C			
Relative Humidity	Non-condensing			90		%	
Vibration	Maximum (power on)			20			
Shock	Maximum (non-operational)			50		g	7

Fiber & Cable	Singlemode 9/125 μm	Multimode 62.5/125 μm	Units	Notes
Fiber Types	9/125	62.5/125, 50/125	μm	
Cable Type (Tight Buffer)	900		μm	
Connector Types Available	Pigtail (standard), FC, SC, ST, LC			
Lead Lengths	1 (standard), 0.5, 2			meter

Electrical	5V (standard)	3V	5V High Current	Units	Notes
Design voltage	5	3	5	volts	
Typical current	50	86	100	mA	
Switch Voltage	4.2 – 6.0	2.5 – 4	4.2 – 6.0	volts	
Coil Resistance	100 ± 10%	35 ± 10%	50 ± 10%	ohm	8
Electrical Interface	3 pin header 0.1 spacing				9

Packaging	Value	Units	Notes
Width	1.6	inches	
Depth	1.4	inches	
Height	0.55	inches	
Weight (Excluding connectors)	1.6	ounces	

Table 1: Switch Specification Summary

Specifications are subject to change without notification
NOTES:

- Insertion loss is measured without connectors
- The switch has a typical electrical to optical transition time of about 6 milliseconds with a settling time of about 1 millisecond at the design drive voltage.
- The maximum is specified to account for minor variations in each switch. At the extremes of temperature, the settling time will increase by about 3 milliseconds due to the damping characteristics of the switch.
- Cross-talk is specified for any two fibers not in optical alignment.
- The maximum power is limited only by the power handling of the fiber ends prepared with a polished 8° angled end face. (+20 and +23 dBm are respective reference test levels only.) For higher power qualification levels, please consult the factory.
- Optical continuity maintained. For the latching option state change does not occur: this value is reduced to 10 G's when power is not applied.
- Half-sine impulse, optical continuity not guaranteed. For the latching option state change may occur. Direction of maximum sensitivity to acceleration: X
- A single coil is used for the non-latching option. The latching option uses two coils in a center-tapped configuration. Examples: 5V default coil is 100 + 100 Ohm = 200 Ohm C.T.
- The switch has three 0.025" square pins on 0.100" centers recessed into the body designed for use with a low profile socket (SAMTEC #SSA-103-S-G or equivalent). One socket is supplied with each switch.

